

AC7103D Datasheet

Zhuhai Jieli Technology Co.,LTD

Version V1.2

Date 2025.04.16

Copyright © Zhuhai Jieli Technology Co.,LTD. All rights reserved.

Revision History

Date	Revision	Description
2025.01.15	V1.0	Initial Release
2025.03.14	V1.1	Update IC Marking Information
2025.04.16	V1.2	Update Datasheet Format Update Package Information



Table of Contents

Revision History	1
Table of Contents	2
AC7103D Features	3
1 Block Diagram	5
2 Pin Definition	6
2.1 Pin Assignment	6
2.2 Pin Description	7
2.3 Pin Specialist	8
3 Electrical Characteristics	9
3.1 Absolute Maximum Ratings	9
3.2 ESD Ratings	9
3.3 PMU Characteristics	9
3.4 Battery Charge	10
3.5 IO Characteristics	10
3.6 Audio DAC Characteristics	11
3.7 Audio ADC Characteristics	13
3.8 BT Characteristics	14
4 Package Information	15
4.1 QFN20L_3×3mm	15
5 IC Marking Information	16
6 Solder-Reflow Condition	17

AC7103D Features

SYSTEM

- 32bit Single-core DSP 192MHz
- On-chip SRAM 280kbyte(share Cache 40k)
- With IEEE754 Single precision FPU
- Support FFT/MATRIX/MAT
- I-cache and D-cache
- Support EMU
- Support MMU
- Support MPU
- Built-In Flash
- 24MHz crystal oscillator
- Internal RC oscillator,PLL

DSP Audio Processing

- SBC/AAC/LDAC/LHDC/LC3/CVSD/mSBC codec
- mSBC voice codec supported for BT phone
- PLC for voice processing
- Single/Dual MIC ENC
- Multi-band DRC
- Multi-band EQ
- Support spatial sound
- Support assistive listening
- Support Hi-Res Audio

ANC

- Wide band digital adaptive ANC
- Support hybrid/feedforward/feedback
- Support wind noise detection
- Support wide area tap
- Support Speak-to-Chat
- Support tip fit test & wear detection
- Input-to-output latency
 - ❖ 10us@SR=750kHz
 - ❖ 14us@SR=375kHz

Audio

- 1 x 24bit DAC
 - ❖ SNR 107dB
 - ❖ Noise 2.5uVrms
 - ❖ Supports differential mode
 - ❖ Sampling rate 8~384kHz

- 2 x 24bit ADC
 - ❖ SNR 100dB
 - ❖ Sampling rate 8~192kHz
- 1 x I²S AUDIO Master/Slave interface
 - ❖ Sampling rate 8~384kHz
 - ❖ Support TX and RX
 - ❖ Support multi-slot mode(TDM)
- 1 x PDM AUDIO Slave interface
 - ❖ Sampling rate 8~192kHz
 - ❖ 4 x DMIC input

Bluetooth

- Dual-mode BT6.0 with LE Audio (DN Q332415)
- Support AoA
- Support LE audio BIS/CIS
- Maximum transmitting power 13dBm
- Receiver sensitivity
 - ❖ -94dBm @BR
 - ❖ -95dBm @EDR Π/4 DQPSK
 - ❖ -87dBm @EDR 8DPSK

Peripherals

- 1 x Full speed USB
- 1 x SD host controller
- 4 x Multi-function 32bit timer
- 2 x UART interface
- 1 x I²C Master/Slave interface
- 2 x SPI Master/Slave interface
- 1 x QDEC
- 1 x 10bit ADC(6 Channels)
- 4 x MCPWM
- 2 x LP_Touch with low power wake up
- 4 x IR RX
- 8 x GPIO Support function remapping

PMU

- Integrated battery charger up to 225mA
- 1 x Buck DC-DC converter
- Support temperature sensor
- VPWR range 4.5V to 5.5V

- VBAT range 2.7V to 4.5V
- IOVDD range 2.7V to 3.6V
- TWS Power < 4.4mA
@AAC No-Load VBAT=3.7V

Packages

- QFN20L(3mm*3mm)

Temperature

- Operating temperature
TC = -20°C to +85°C (standard range)
TC = -40°C to +105°C (extended range)
- Storage temperature -65°C to +150°C

Applications

- ANC TWS/OWS
- Bluetooth audio device

1 Block Diagram

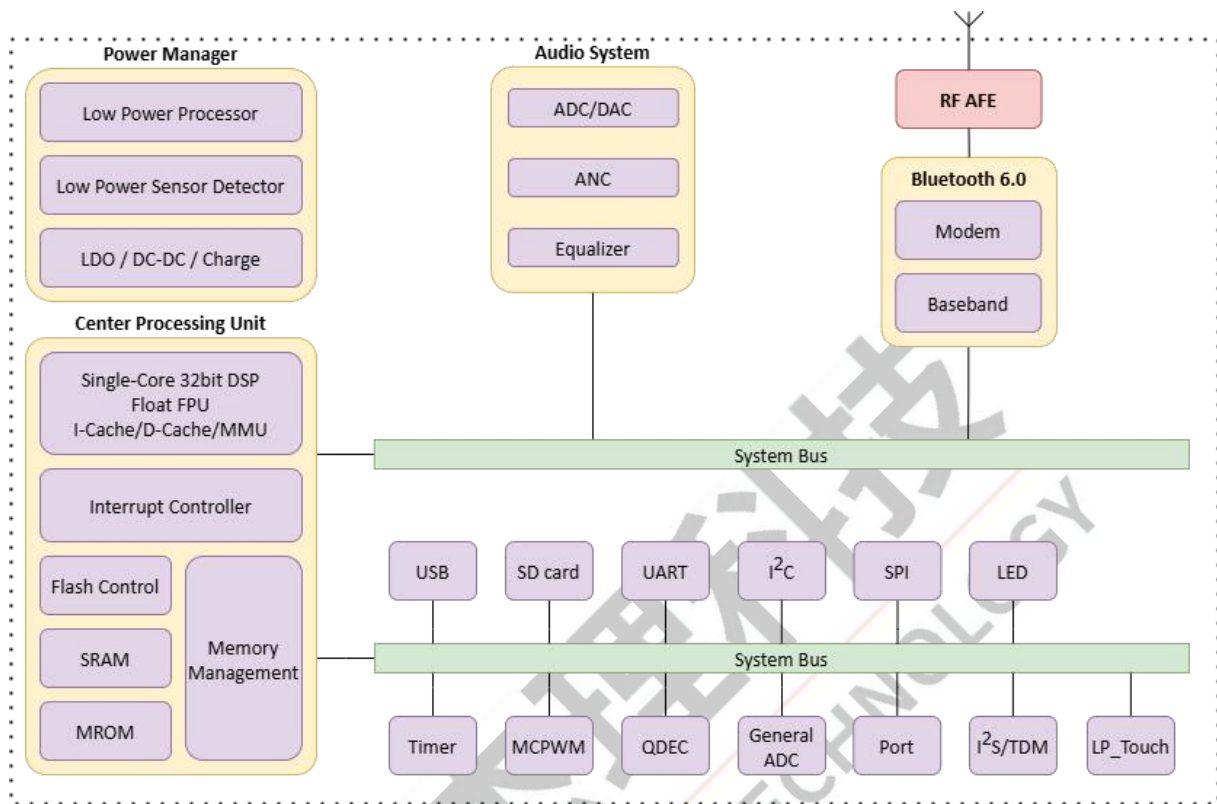

Figure 1-1 AC7103D Block Diagram

2 Pin Definition

2.1 Pin Assignment

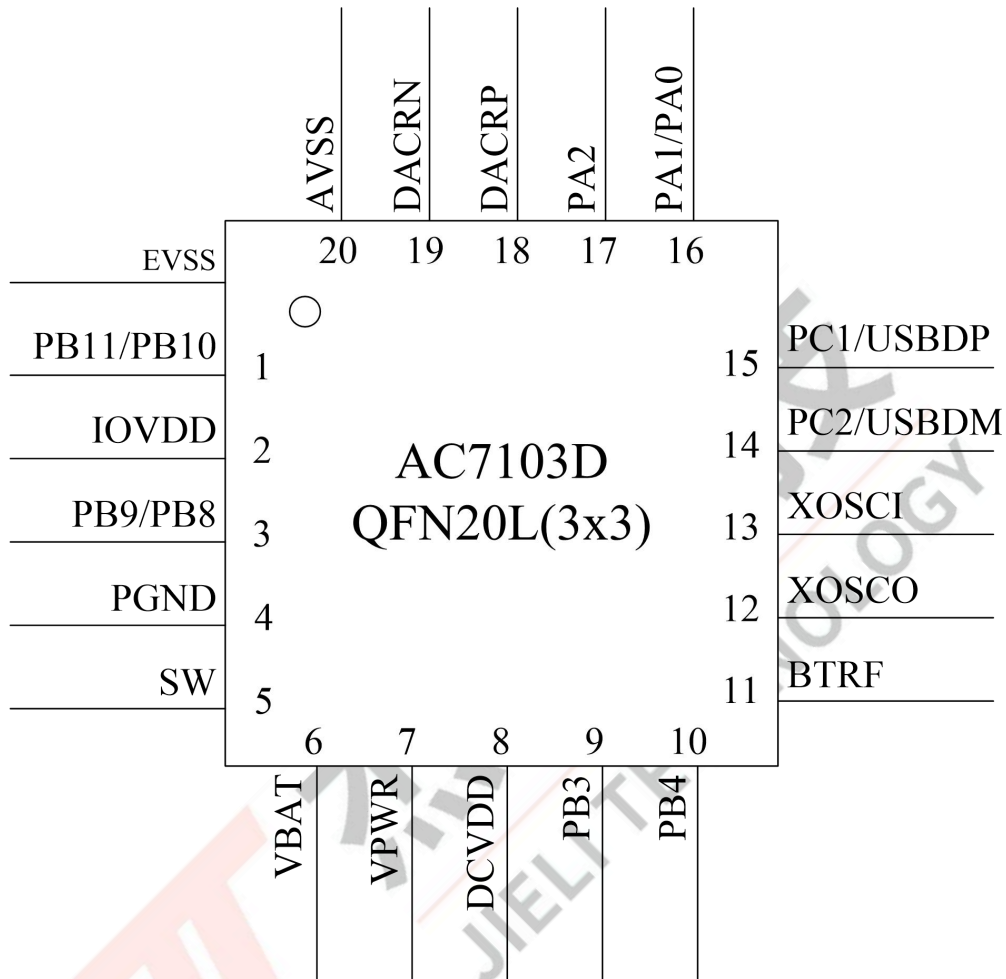

Figure 2-1 AC7103D Pin Assignment

2.2 Pin Description

Table 2-2-1 AC7103D Pin Description

Pin No.	Name	Type	IO Initial State	Description
1	PB11	I/O	Z	MICBIASB(MIC Bias Output) MIC_B0(MIC Input)
	PB10	I/O	Z	AIN_B0(Audio ADC Positive Input)
2	IOVDD	P	--	IO Power
3	PB9	I/O	Z	AIN_B1(Audio ADC Positive Input) AIN_BN(Audio ADC Negative Input)
	PB8	I/O	Z	ADC12(ADC Input Channel 12)
4	PGND	G	--	Ground of Buck DC-DC converter
5	SW	P	--	Buck DCDC Switch Port
6	VBAT	P	--	Battery Input
7	VPWR	P	--	Charge Power Input
8	DCVDD	P	--	1.25V DCDC Power
9	PB3	I/O	Z	LP_TOUCH4(TOUCH_CH4) ADC10(ADC Input Channel 10)
10	PB4	I/O	10kΩ Pull-up	Hold down 0 to reset LP_TOUCH5(TOUCH_CH5) ADCP0(GPADC Input Channel P0)
11	BTRF	RF	--	Bluetooth RF Antenna
12	XOSCO	O	--	Crystal Oscillator Output
13	XOSCI	I	--	Crystal Oscillator Input
14	PC2	I/O	Z	ADC1(ADC Input Channel 1)
	USBDM	I/O	15kΩ Pull-down	USB Negative Data ADC15(ADC Input Channel 15)
15	PC1	I/O	Z	ADC0(ADC Input Channel 0)
	USBDP	I/O	15kΩ Pull-down	USB Positive Data ADC14(ADC Input Channel 14)
16	PA1	I/O	Z	AIN_A0(Audio ADC Positive Input)
	PA0	I/O	Z	MICBIASA(MIC Bias Output) MIC_A0(MIC Input)
17	PA2	I/O	Z	AIN_A1(Audio ADC Positive Input) AIN_AN(Audio ADC Negative Input)
18	DACRP	P	--	Right Channel DAC Positive Output
19	DACRN	P	--	Right Channel DAC Negative Output
20	AVSS	G	--	Audio Ground

Note

1.IO initial state abbreviations Z--High resistance, H--High level, L--Low level, X--May be changed during power on.

2.Timer, MCPWM, QDEC, UART, LEDC, I²C, I²S, SPI,IR RX and SD functions can be remapped to any I/O.

Table 2-2-2 Pin Types Description

Pin Type	Description	Pin Type	Description
P	Power	I/O	Input or Output
G	Ground	I	Input
RF	RF antenna	O	Output

2.3 Pin Specialist

Table 2-3 Pin keep Description

Pin	Description for IOVDD power off mode
PC1	Support driving and sampling external 100kΩ NTC resistance in single IO
PB4	10kΩ Pull-up and Hold down 0 to reset function can be disable by efuse in IO Initial State

3 Electrical Characteristics

3.1 Absolute Maximum Ratings

Table 3-1 Absolute Maximum Ratings

Symbol	Parameter	Min	Max	Unit
Topt	Operating temperature	-20	+85	°C
Tstg	Storage temperature	-65	+150	°C
VBAT	Supply Voltage	-0.3	4.5	V
VPWR		-0.3	6	V
IOVDD		-0.3	3.6	V
DCVDD		-0.3	1.55	V
GPIO	Input voltage of GPIO	-0.3	3.6	V

Note

1. Stresses beyond those listed under absolute maximum ratings may cause permanent damage to the device.

3.2 ESD Ratings

Table 3-2 ESD Ratings

Parameter	Typ	Test pin	Reference standard
Human Body Mode	±4kV	All pins	JEDEC EIA/JESD22-A114
Machine Mode	±300V	All pins	JEDEC EIA/JESD22-A115
Charge Device Model	±2kV	All pins	ANSI/ESDA/JEDEC JS-002-2022

3.3 PMU Characteristics

Table 3-3 PMU Characteristics

Symbol	Parameter	Conditions	Min	Typ	Max	Unit
VBAT	Power supply	--	2.7	3.7	4.5	V
VPWR	Power supply	--	4.5	5.0	5.5	V
Operating mode						
Symbol	Parameter	Conditions	Min	Typ	Max	Unit
IOVDD	Voltage output	--	--	3	--	V
	Loading current	IOVDD=3.0V@VBAT = 3.7V or VPWR=5V	--	--	120	mA
DCVDD	Voltage output	--	--	1.25	--	V
	Loading current	DCVDD=1.25V@IOVDD=3.0V in LDO mode	--	--	120	mA
		DCVDD=1.25V@VBAT=3.7V in DCDC mode	--	--	120	mA
Low Power mode						
Symbol	Parameter	Conditions	Min	Typ	Max	Unit
IOVDD	Loading current	IOVDD=3.0V@VBAT = 3.7V or VPWR=5V	--	--	10	mA

3.4 Battery Charge

Table 3-4 Charger Characteristics

Symbol	Parameter	Min	Typ	Max	Unit
VPWR	Charge Input Voltage	4.5	5	5.5	V
CV	CV Mode Voltage Accuracy	4.175	4.2	4.225	V
		4.375	4.4	4.425	V
		4.475	4.5	4.525	V
CC	CC Mode Current	30	--	225	mA
I _{end}	End Of Charge Current	3	--	22.5	mA
V _{Trickl}	Trickle Charge Voltage	--	3	--	V

3.5 IO Characteristics

Table 3-5 IO Characteristics

Input Characteristics						
Symbol	Parameter	Conditions	IO	Min	Max	Unit
V _{IL}	Low-Level Input Voltage	IOVDD = 3.0V	PA0~PA2 PB3,PB4,PB8,PB9,PB10,PB11 PC1,PC2 VPWR USBDP USBDM	-0.3	1.3	V
V _{IH}	High-Level Input Voltage	IOVDD = 3.0V	PA0~PA2 PB3,PB4,PB8,PB9,PB10,PB11 PC1,PC2 USBDP USBDM	1.7	3.3	V
		IOVDD = 3.0V	VPWR	1.7	5.5	V
Output Characteristics						
Symbol	Parameter	Conditions	IO	Typ	Unit	
I _{OL}	Output Current	IOVDD = 3.0V Voutput = 0.3V	PA0~PA2 PB3,PB4,PB8,PB9,PB10,PB11 PC1,PC2	1(HD=0) 4(HD=1) 8(HD=2) 31(HD=3)	mA	
		IOVDD = 3.0V Voutput = 0.3V	USBDP USBDM	8	mA	
		IOVDD = 3.0V Voutput = 0.3V	VPWR	2	mA	
I _{OH}	Output Current	IOVDD = 3.0V Voutput = 2.7V	PA0~PA2 PB3,PB4,PB8,PB9,PB10,PB11	1(HD=0) 4(HD=1)	mA	
			PC1,PC2	8(HD=2)		

				31(HD=3)	
		IOVDD = 3.0V Voutput = 2.7V	USBDP USBDM	8	mA
		IOVDD = 3.0V Voutput = 2.7V	VPWR	2	mA
Internal Resistance Characteristics					
Symbol	Parameter	Conditions	IO	Typ	Unit
R _{pu}	Pull-up Resistance	IOVDD = 3.0V	PA0~PA2 PB3,PB4,PB8,PB9,PB10,PB11 PC1,PC2 VPWR	10k(PU=1) 200k(PU=2) 1M(PU=3)	Ω
		IOVDD = 3.0V	USBDP	1.5k 10k(PU=1) 200k(PU=2) 1M(PU=3)	Ω
		IOVDD = 3.0V	USBDM	180k 10k(PU=1) 200k(PU=2) 1M(PU=3)	Ω
R _{pd}	Pull-down Resistance	IOVDD = 3.0V	PA0~PA2 PB3,PB4,PB8,PB9,PB10,PB11 PC1,PC2 VPWR	10k(PD=1) 200k(PD=2) 1M(PD=3)	Ω
		IOVDD = 3.0V	USBDP USBDM	15k 10k(PU=1) 200k(PU=2) 1M(PU=3)	Ω

Note

1. Internal pull-up/pull-down resistance accuracy ±20%

3.6 Audio DAC Characteristics

Table 3-6-1 DAC Characteristics (HPVDD Under 1.55V)

Parameter	Conditions	Min	Typ	Max	Unit
Resolution	--	--	24	--	bits
Input Sample Rate	--	8	--	384	kHz
SNR ^①	Differential Mode Fin=1kHz@0dBFS Fs=44.1kHz B/W=20Hz~20kHz A-Weighted		107	--	dB
Dynamic Range	Differential Mode Fin=1kHz@-60dBFS		103	--	dB

	Fs=44.1kHz B/W=20Hz~20kHz A-Weighted					
THD+N	Differential Mode Fin=1kHz@0dBFS Fs=44.1kHz B/W=20Hz~20kHz A-Weighted	HPVDD=1.25V Load=32Ω	--	-80	--	dB
Noise Floor	Differential Mode Fin=1kHz@0dBFS Fs=44.1kHz B/W=20Hz~20kHz A-Weighted	HPVDD=1.25V Load=10kΩ	--	3.8	--	uVrms
Noise Floor with MUTE	Differential Mode Fin=1kHz@0dBFS Fs=44.1kHz B/W=20Hz~20kHz A-Weighted	HPVDD=1.25V Load=10kΩ	--	2.5	--	uVrms
Max Output Power	Differential Mode Fin=1kHz@0dBFS Fs=44.1kHz B/W=20Hz~20kHz A-Weighted THD+N<0.1%	HPVDD=1.25V Load=16Ω	--	20	--	mW
		HPVDD=1.55V Load=16Ω	--	47	--	mW

Note

- ① SNR is the ratio of output level with a 1kHz full-scale input to output level with MUTE on.

3.7 Audio ADC Characteristics

Table 3-7 Audio ADC Characteristics

Parameter	Conditions	Min	Typ	Max	Unit
Resolution	--	--	24	--	bits
Output Sample Rate	--	8	--	192	kHz
SNR	Differential input Mode Fin=1kHz@0dBFS Fs=44.1kHz B/W=20Hz~20kHz A-Weighted ADC gain=0dB	--	100	--	dB
	Single-ended input Mode Fin=1kHz@0dBFS Fs=44.1kHz B/W=20Hz~20kHz A-Weighted ADC gain=0dB	--	93	--	dB
Dynamic Range	Differential input Mode Fin=1kHz@-60dBFS Fs=44.1kHz B/W=20Hz~20kHz A-Weighted ADC gain=0dB	--	100	--	dB
	Single-ended input Mode Fin=1kHz@-60dBFS Fs=44.1kHz B/W=20Hz~20kHz A-Weighted ADC gain=0dB	--	93	--	dB
THD+N	Differential input Mode Fin=1kHz@0dBFS Fs=44.1kHz B/W=20Hz~20kHz A-Weighted ADC gain=0dB	--	-90	--	dB
	Single-ended input Mode Fin=1kHz@0dBFS Fs=44.1kHz B/W=20Hz~20kHz A-Weighted ADC gain=0dB	--	-88	--	dB
Analogue Gain	--	-6	--	27	dB
Max Input Level	Differential input Mode ADC gain=0dB	--	0.56	--	Vrms
	Single-ended input Mode ADC gain=0dB	--	0.28	--	Vrms

3.8 BT Characteristics

3.8.1 Transmitter

Table 3-8-1 Transmitter characteristics

Parameter	Conditions	Min	Typ	Max	Unit
Maximum RF Transmit Power	BR	--	10	13	dBm
Maximum RF Transmit Power	EDR $\pi/4$ DQPSK EDR 8DPSK	--	10	--	dBm
Relative Transmit Power	EDR $\pi/4$ DQPSK EDR 8DPSK	--	1	--	dB
Maximum RF Transmit Power	BLE-1Mbps	--	10	--	dBm
1 σ of Maximum RF Transmit Power distribution	BR/EDR/BLE	--	2	--	dB

3.8.2 Receiver

Table 3-8-2 Receiver characteristics

Parameter	Conditions	Min	Typ	Max	Unit
Sensitivity	BR	--	-94	--	dBm
	EDR $\pi/4$ DQPSK	--	-95	--	dBm
	EDR 8DPSK	--	-87	--	dBm
	BLE-1Mbps	--	-97	--	dBm
	BLE-2Mbps	--	-93	--	dBm
1 σ of sensitivity distribution	BR/EDR/BLE	--	2	--	dB

4 Package Information

4.1 QFN20L_3×3mm

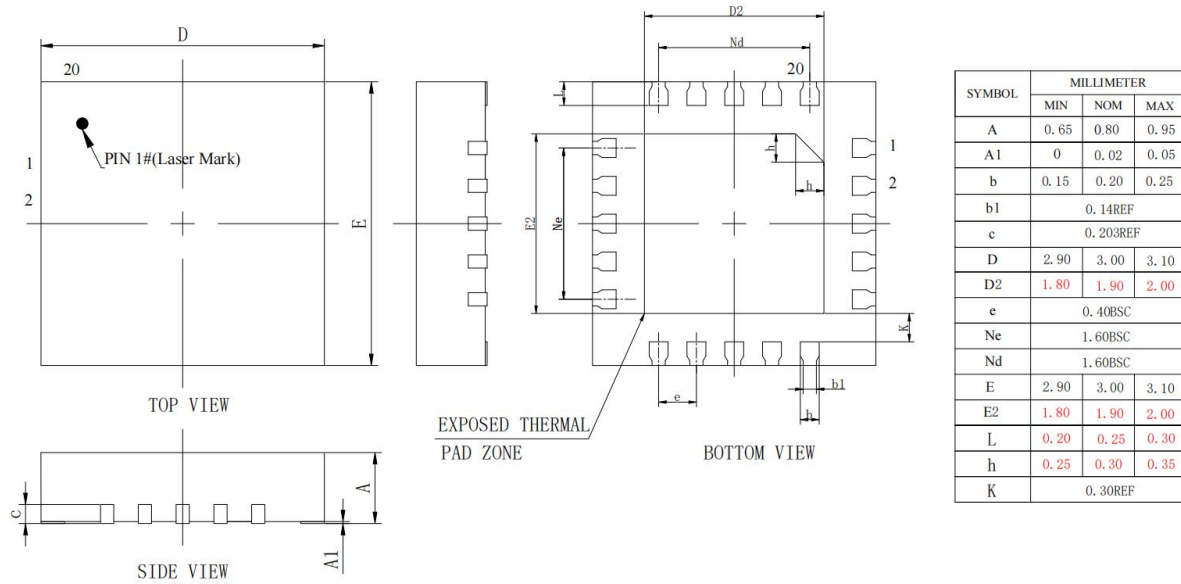

Figure 4-1 AC7103D Package

5 IC Marking Information

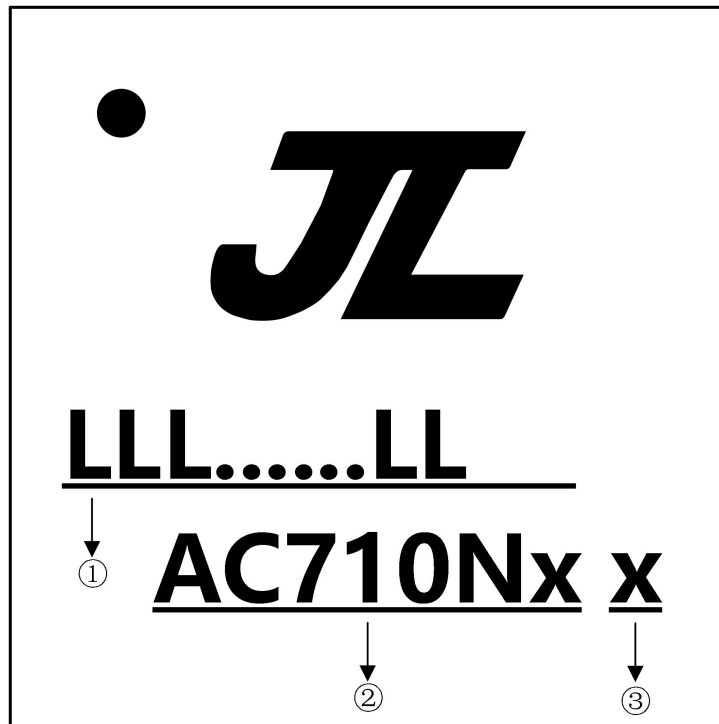

Figure 5-1 AC7103D Package Outline

- ① LLL.....LL Production Batch
- ② AC710Nx Chip Model
- ③ x Built-in flash size
 - 4 4Mbit Flash
 - 8 8Mbit Flash
 - 6 16Mbit Flash

6 Solder-Reflow Condition

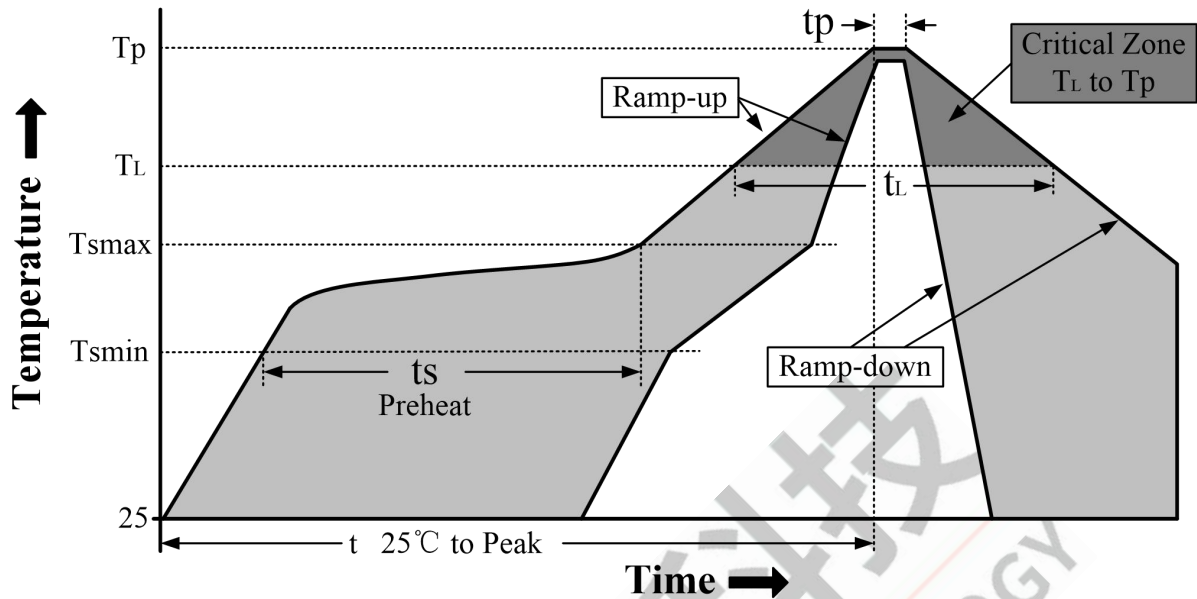

Figure 6-1 Classification Reflow Profile

Table 6-1 Classification Profiles

Profile Feature		Sn-Pb Eutectic Assembly	Pb-Free Assembly
Preheat/Soak	Temperature Min (T_{smin})	100°C	150°C
	Temperature Max (T_{smax})	150°C	200°C
	Time (t_s) from (T_{smin} to T_{smax})	60-120 seconds	60-180 seconds
Average ramp-up rate (T_{smax} to T_p)		3°C/second max	3°C/second max
Liquidous temperature (T_L)		183°C	217°C
Time (t_L) maintained above T_L		60-150 seconds	60-150 seconds
Peak package body temperature (T_p)		See Table 6-2	See Table 6-3
Time within 5°C of actual Peak Temperature (t_p) ²		10-30 seconds	20-40 seconds
Ramp-down rate (T_p to T_L)		6°C/second max	6°C/second max
Time 25°C to peak temperature		6 minutes max	8 minutes max

Note

- 1.All temperatures refer to topside of the package, measured on the package body surface
- 2.Time within 5°C of actual peak temperature (t_p) specified for the reflow profiles is a “supplier” and “user” maximum.

Table 6-2 SnPb Classification Temperature

Package Thickness	Volume mm ³	Volume mm ³
	< 350	≥ 350
<2.5 mm	240 +0/-5°C	225 +0/-5°C
≥2.5 mm	225 +0/-5°C	225 +0/-5°C

Table 6-3 Pb-free - Classification Temperature

Package Thickness	Volume mm ³ < 350	Volume mm ³ 350 - 2000	Volume mm ³ > 2000
< 1.6mm	260°C	260°C	260°C
1.6 mm - 2.5mm	260°C	250°C	245°C
> 2.5mm	250°C	245°C	245°C

Note

1.*Tolerance The device manufacturer/supplier shall assure process compatibility up to and including the stated classification temperature (this means Peak reflow temperature +0°C.For example 260°C+0°C)at the rated MSL level.

